



## **Guidelines for Light Partner Applicants**

### **“B Light Scheme”**

**(Fostering value added business cooperation between SMEs operating on different sides of the Hungary-Croatia border)**

**to be implemented under Priority 1 of  
Interreg V-A Hungary-Croatia Co-operation Programme 2014-2020**

**Version 4.0  
October 2020**

*Service contract No. 143ST-2015HR*

*Contracting Authority:*

Széchenyi Programme Office Consulting and Service Nonprofit Ltd. (1053 Budapest, Szép u. 2.)

## Contents

Contents .....	2
1. Introduction .....	4
1.1. Programme background.....	4
1.2. Legal background .....	5
1.3. Purpose and structure of the Guidelines for Light Partner Applicants.....	6
2. Implementation structure .....	7
2.1. Programme level bodies .....	7
2.2. Beneficiaries – SME development agencies.....	8
2.3. Light Partners – the cooperating SMEs .....	10
2.4. External project support facility – technical assistance to the cooperating SMEs .....	11
2.5. First level control .....	12
3. Eligibility of Light Partner applicants .....	13
3.1. Legal status.....	13
3.2. Geographical location .....	13
3.3. Professional and financial background .....	14
3.4. Partnership requirements.....	14
3.5. Exclusion criteria .....	15
4. State aid rules.....	17
5. Eligibility of activities of Light Partners.....	20
5.1. Eligible activities.....	20
5.2. Eligible levels of cooperation.....	22
6. Co-financing of Light Projects.....	24
6.1. Type of co-financing.....	24
6.2. Co-financing rate.....	24
6.3. Own contribution .....	24
6.4. Light Project size.....	24
7. Eligibility of costs of Light Partners .....	25
7.1. Preparation costs .....	25
7.2. Staff costs .....	25
7.3. Office and administrative expenditure.....	28
7.4. Travel and accommodation expenses .....	28
7.5. External expertise and services .....	29

7.6.	Equipment.....	30
7.7.	Infrastructure and works.....	31
7.8.	Ineligible expenditure .....	32
8.	Evaluation and selection of Light Projects .....	34
8.1.	Light Project Proposals .....	35
8.2.	Evaluation grids .....	37
8.3.	Selection Board.....	40
8.4.	Contracting.....	41
9.	Implementation and monitoring.....	42
9.1.	Project duration .....	42
9.2.	Sustainability period .....	42
9.3.	Advance payment .....	42
9.4.	Financial guarantee .....	42
9.5.	Reporting procedures .....	42
9.6.	Role of the EPSF during management and reporting .....	44
9.7.	Procurement rules.....	44
9.8.	Communication requirements .....	45
10.	Administrative requirements for infrastructure and works elements of Light Project .....	47
10.1.	Documents to be attached in case of Light Projects with infrastructure and works elements .....	47
10.2.	Ownership issues of land and buildings subject to infrastructure and works components of projects .	
49	Glossary .....	52
ANNEX I.	.....	53
ANNEX II.	.....	57

# 1. Introduction

## 1.1. Programme background

Recognising the need for economic development, one pillar of the strategy for the 2014-2020 cross-border cooperation programme between Hungary and Croatia became fostering value added business cooperation between SMEs operating on different sides of the border.

Priority axis 1 of the Interreg V-A Hungary-Croatia Co-operation Programme 2014-2020 aims to enhance the competitiveness of small and medium-sized enterprises (SMEs) in the border region.

Analysis has clearly shown that Hungarian and Croatian SMEs have not been able to recover from the shock of the economic crisis. Several analyses revealed that enterprises of the programme area have financial, innovation and networking problems. Weak internationalisation is one of the most crucial hindering factor which is especially true for the SMEs of the programme area with no improvement in the past years. Cross-border business cooperations in the programme area have multiple obstacles: language barrier, traditionally isolating borders hampered by the wartime period of the formerly Yugoslav countries, depressed socio-economic situation of the area, low inclination of SMEs for building international connections, serious problems with entrepreneurial skills and financing.

These cumulative problems could be addressed by a special local SME development scheme fostering development of local SMEs with strong focus on value added improvement via improving their financial background and simultaneously enhancing their cross-border business cooperations with high attention to provision of an all-round set of assistance to cooperating SMEs with built-in SME project generation and management services.

Investment priority focuses on fostering value added producing capability of enterprises operating in industry and services by boosting their product and service development activities through joint economic development actions which could generate higher gross value added (GVA) and consequently makes it possible to find new markets. By assistance of special development scheme SMEs are expected to develop joint projects aiming at establishing the following types of business cooperation: joint product, technology and service development, supplier chains, common marketing, future establishment of a joint venture. By enhancing business cooperation focusing on joint product and service developments, value added production of cooperating SMEs is expected to be improved in the bordering area. In general, it will help SMEs to become more stable and profitable in the border region that is expected to have a positive impact on employment, too. New business services to be made available for tourists visiting the natural and cultural attractions of the border area will contribute to increased attractiveness of the region and to increased revenues from and employment linked to tourism.

Crucial element of this special SME development scheme is built-in project generation and management support for cooperating SMEs based on the existing SME support networks with involvement of development agencies and enterprise development foundations operating in the programme area. This new SME development scheme enlarges the scope of their SME support activities in a complementary way (e.g. the new scheme amplifies the impact of existing micro-credit scheme of Hungarian enterprise development foundations). This special cooperation-driven SME development scheme could also serve as complementary set of actions to the SME development instruments of national mainstream programmes. Main complementarity of this scheme lies in the strong focus on SME project generation and management assistance with a built-in mentoring mechanism supporting SMEs in their project activities through the whole duration of project implementation.

Indicator	Measurement unit	Baseline	Target 2018	Target 2023
Average GVA per capita of industry and services sectors of the programme area	EUR	5,208.00	-	5,500.00
Number of enterprises receiving support	Enterprises	0	-	80
Number of enterprises receiving grants	Enterprises	0	15	80
Number of enterprises receiving non- financial support	Enterprises	0	-	80
Scheme spending (financial indicator)	EUR	0	2,200,000.00	11,718,000.00

## 1.2. Legal background

**The B Light Scheme is an SME development funding scheme** specially designed for European Territorial Cooperation (ETC) and cross-border cooperation (CBC) programmes.

Technically, it acts as one single CBC project implemented by a consortium of project partners that changes (grows) throughout the project period. The project is initiated and launched by the Project Partners (PPs): the Lead Beneficiary (LB) and the Beneficiaries (Bs), which are enterprise development agencies from the two sides of the border. The PPs submit the B Light Scheme project proposal and, after the project was approved by the Monitoring Committee, LB signs a Subsidy Contract with the Managing Authority and the LB and the Bs parallelly sign a Partnership Agreement as an Annex to the Subsidy Contract. All these steps have already been carried out: Subsidy Contract of B Light Scheme project has been signed by the LB of the Scheme (HAMAG-BICRO) and all 7 county development agencies as Beneficiaries of the Scheme have been appointed (see Chapter 2.2.). This set the basis of the launch of the Scheme operation.

**SMEs enter the Scheme after a call for proposal selection procedure as Light Partners (B Lights)** by signing the Partnership Agreement with the LB. As more and more SMEs enter the Scheme, the partnership grows bigger and bigger.

In the project, the LB and the Bs manage the Scheme and provide different business support and consultancy services to SMEs (see Chapter 2.4.). Light Partners implement joint investment projects to establish new business cooperations.

Financial allocation for Light Partners is included in the budget of the B Light Scheme project as lump sum as if Light Partners would be one single project partner. Later, as SMEs enter the partnership, this latter part of the budget is gradually allocated to them as Light Partners.

### 1.3. Purpose and structure of the Guidelines for Light Partner Applicants

The purpose of this Guidelines is to provide an overall description of the operation of the B Light Scheme to be implemented under Priority 1 of the Interreg V-A Hungary-Croatia Cooperation Programme 2014-2020 and shall serve as a basis for all activities of the Light Partners: their selection procedure, the eligible activities and costs of the Light Projects and all other relevant information on the Calls for Proposals.

However, the Guidelines for Light Partner Applicants is not designed to provide the totality of the information necessary for the implementation of the Light Projects. Actually, it is presumed and required that Light Partners have a thorough knowledge of the CBC context in which the B Light Scheme and the Light Projects are implemented, and especially on the content of the Cooperation Programme itself, all relevant community and national legislation (including, among others, the rules of ERDF and ETC implementation, state aid rules, public procurement legislation etc.) and programme implementation documents.

**The modified 4.0 version of this Guidelines is applicable for the 4th Call for Light Project Proposals published within the B Light Scheme to be implemented under Priority 1 of the Interreg V-A Hungary-Croatia Cooperation Programme 2014-2020.**

## 2. Implementation structure

### 2.1. Programme level bodies

In respect of the B Light Scheme, the following bodies have responsibilities in the implementation:

- Monitoring Committee

The Monitoring Committee (MC) is the main decision making body of the Interreg V-A Hungary-Croatia Cooperation Programme, composed of the representatives of the programme area counties and the responsible state bodies. The MC is responsible to approve the Scheme, as a special project and monitor its implementation, making decision on changes in line with the Subsidy Contract.

The MC shall have the following specific tasks related to the Scheme:

- decision on content of the Calls for Light Project Proposals, including the evaluation system;
- half-year supervision of B Light Scheme implementation and proceedings, especially in terms of meeting the indicators and absorption of funds available;
- approval of changes on level of the Scheme;
- approval of annual reports on progress of the B Light Scheme.

Working body of the MC is the Joint Secretariat (JS). The JS shall be supported by the Lead Beneficiary (HAMAG-BICRO), providing all necessary information on the proceedings of the B Light Scheme.

- The Managing Authority

The Managing Authority (MA) bears overall responsibility for the implementation of the Cooperation Programme, including the Scheme. The MA is the Ministry of Foreign Affairs and Trade of Hungary, based in Budapest. The MA acts as signatory of the Subsidy Contract of the Scheme, having responsibility and competences in monitoring it in line with the Subsidy Contract.

As tasks in connection with management of the application procedure of the Light Projects are carried out by the Scheme's partnership (i.e. the Beneficiaries, see Chapter 2.2.), the MA has no role in evaluation of Light Project Proposals, however supervises selection procedure delegating non-voting member to the Selection Board.

#### ▫ National Authority

The National Authority (NA) In cooperation with the joint programme structures, on behalf of the Member State, the NA is responsible for the preparation, implementation and monitoring of the Programme on national level. The NA is the Ministry of Regional Development and EU Funds of the Republic of Croatia, based in Zagreb. The NA has the role of supervising project selection procedures by delegating a non-voting member to the Selection Board

#### ▫ Certifying Authority

The Certifying Authority (CA) is responsible for certifying declarations of expenditure and applications for payment, including the Scheme as well.

#### ▫ Audit Authority

The Audit Authority (AA) is independent from the MA and the CA, responsible for verifying the effective functioning of the management and control system, including control of the Scheme and the Light Projects as well.

#### ▫ Joint Secretariat

The Joint Secretariat (JS) is the administrative body supporting the MA, the MC and the SC. The JS is set up at the Széchenyi Programme Office Nonprofit Llc., headquartered in Budapest, but having contact points in Čakovec, Osijek and Pécs. As the Scheme is a project in itself, the JS is responsible for administrative monitoring of it. Scheme level progress reports, final report and application for reimbursements after each project period (trimester) shall be sent to the JS, followed by a procedure of approval regulated by the Subsidy Contract. The JS has also responsibilities in endorsing changes on level of the Scheme, stipulated by the Subsidy Contract.

As tasks in connection with management of the application procedure of the Light Projects are carried out by the Scheme's partnership (i.e. the Beneficiaries, see Chapter 2.2.), the JS has no role in evaluation of Light Project Proposals, however supervises selection procedure delegating non-voting member to the Selection Board.

## 2.2. Beneficiaries – SME development agencies

The Scheme in terms of partnership matches general cross-border projects: having a Lead Beneficiary and several Beneficiaries.

#### ▫ Lead Beneficiary: HAMAG-BICRO

HAMAG-BICRO – Hrvatska agencija za malo gospodarstvo, inovacije i investicije  
(Croatian Agency for SMEs, Innovations and Investments)

Address: Ksaver 208, Zagreb | Phone: +385 1 4881001 | E-mail: hamagbicro@hamagbicro.hr

The Lead Beneficiary (LB) bears responsibility for overall coordination of the implementation of the Scheme, in line with the Subsidy Contract signed with the MA.

The LB is responsible for the sound and prudent management of the selection of the Light Partners.). Light

Partners of the selected Light Projects shall sign a Partnership Agreement with the LB.

The LB operates the online B Light Platform as the official web portal of the Scheme. The Light Projects can be submitted online through this B Light Platform.

The LB is obliged to sound administrative and financial management of the Scheme, including submission of the Scheme level progress reports and final report, accompanied with the payment claims to the JS. All monetary transfers are sent by the JS to the LB, the LB's responsibility is to transfer the grant amounts verified to the Beneficiaries and to the Light Partners (SMEs).

□ Beneficiaries: county level SME development agencies

The Beneficiaries are responsible for coordinating the project activities in their respective counties. 7 Beneficiaries are involved: 1-1 from each of the bordering counties of Hungary and Croatia (see below). As in Croatia only the directly bordering counties' (Koprivnica-Križevci, Međimurje, Osijek-Baranja, Virovitica- Podravina) SME development agencies are involved as Beneficiaries, responsibility of coordinating activities in the further eligible counties (Bjelovar-Bilogora, Požega-Slavonia, Vukovar-Srijem and Varaždin) are to be divided among the Croatian Beneficiaries.

The Beneficiaries' main task is to promote and raise awareness about the Scheme among the SMEs in the border area and play an active role in project generation: organising promotion events, B2B meetings and consultations in order to identify the potential Light Partners and Light Project initiatives.

The Beneficiaries participate in evaluation of Light Project Proposals. Beneficiaries take part in the Selection Board (composed of the LB and the 7 Beneficiaries) responsible for selection of the Light Project Proposals.

Avoidance of conflict of interest: staff involved in the evaluation phase from side of the Bs should be different from the persons involved in generation of the Light Project Proposals.

<b>Hungary</b>
<i>Baranya county:</i>  Baranya Megyei Fejlesztési Ügynökség Nonprofit Kft. (Baranya County Development Agency Non-profit Ltd.)  Address: 7621 Pécs, Széchenyi tér 9.   Phone: +36 72 500455   E-mail: trombitas.karoly.zoltan@gmail.com
<i>Somogy County:</i>  Somogy Megyei Vállalkozói Központ Közalapítvány (Entrepreneurs' Centre of Somogy County Public Foundation)  Address: 7400 Kaposvár, Ond vezér u. 1.   Phone: +36 82 527790   E-mail: info@somogy-hvk.hu
<i>Zala County:</i>  Zala Megyei Vállalkozásfejlesztési Alapítvány (Zala County Foundation for Enterprise Promotion)  Address: 8900 Zalaegerszeg, Köztársaság útja 17.   Phone: +36 92 316033   E-mail: infozmva@zmva.hu



<b>Croatia</b>
<p><i>Osijek-Baranja and Vukovar-Srijem counties:</i></p> <p>Javna ustanova Županijska razvojna agencija Osječko-baranjske županije. (Public Institution County Development Agency of Osijek - Baranja County)</p> <p>Address: 31000 Osijek, Stjepana Radića 4   Phone: +385 31 221840   E-mail: regija@obz.hr</p>
<p><i>Virovitica-Podravina and Požega-Slavonia counties:</i></p> <p>VIDRA Agencija za regionalni razvoj Virovitičko-podravske zupanije (VIDRA Virovitica-Podravina County`s Development Regional Agency)</p> <p>Address: 33000 Virovitica, Auguta Šenoa 1   Phone: +385 33 725219   E-mail: info@ravidra.hr</p>
<p><i>Koprivnica-Križevci and Bjelovar-Bilogora counties:</i></p> <p>PORA Razvojna agencija Podravine i Prigorja za promicanje i provedbu razvojnih aktivnosti u Koprivničko-križevačkoj županiji (PORA Regional development agency of Podravina and Prigorje for promotion and implementation of development activities in Koprivnica Križevci County)</p> <p>Address: 48000 Koprivnica, Florijasnki trg 4   Phone: +385 48 621978   E-mail: info@pora.com.hr</p>
<p><i>Međimurje and Varaždin counties:</i></p> <p>Javna ustanova za razvoj Međimurske županije REDEA (Public Institution for the Development of the Međimurje County REDEA)</p> <p>Address: 40000 Čakovec, Bana Josipa Jelačića 22   Phone: +385 40 395560   E-mail: redea@redea.hr</p>

### 2.3. Light Partners – the cooperating SMEs

The Light Partners are the beneficiary SMEs selected through a selection procedure in order to receive a subsidy from the Scheme. The applying Light Partners have to be registered or have to have a branch operating in the programme area of the Cooperation Programme. Once the Light Partners' Light Project has been selected, the Light Partners sign a Partnership Agreement with the LB. Light Partners are mainly responsible for the implementation of their Light Project part and they should cooperate with their Light Partner(s) from the neighbouring country so as to meet their Light Project level indicators set out in their Light Project documentation.

Light Partners are responsible for the sound administrative management of their Light Project parts, including submission of their partner level progress reports and final report to the territorially responsible FLC and provide in-depth information on the project part's activities to the project level progress reports and the final report. In these administrative obligations they will be assisted by the External Project Support Facility (EPSF) whose experts will be contracted by the Lead Beneficiary HAMAG-BICRO.

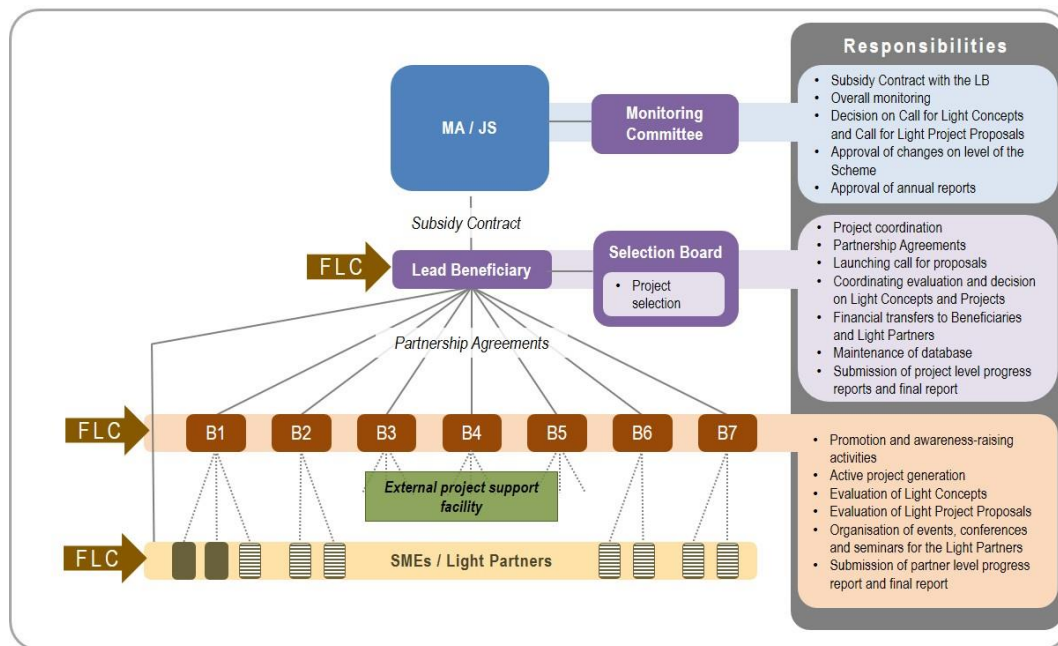

Figure 1: Implementation structure of B Light Scheme.

## 2.4. External project support facility – technical assistance to the cooperating SMEs

As the Scheme – due to its bilateral cross-border character – is a unique initiative, the implementation of the Light Projects require special approach and preparedness from the participating SMEs. In order to cope with these challenges and generate real added value in cross-border economic relations, Light Partners will receive free-of-charge technical assistance by the External Project Support Facility (EPSF).

EPSF has the following assignments:

- Provision of project management assistance to SMEs as Light Partners in coping with the administrative and financial management requirements and the language barrier during implementation of their Light Projects (see Chapter 9.3.).

EPSF is provided by a consortium composed of external SME development experts both from Hungary and Croatia. Experts of the EPSF will be contracted and financed by the LB.

## 2.5. First level control

Verification of expenditures and approval of partner level progress reports is done by the territorially competent First Level Control (FLC). The FLC is delegated to the following bodies:

- In Hungary: Széchenyi Programme Office Llc.: 7621 Pécs, Széchenyi tér 9.; 8900 Zalaegerszeg, Petőfi u. 24.
- In Croatia: Ministry of Regional Development and EU Funds of the Republic of Croatia, 10000 Zagreb, .Miramarska cesta 22

Light Partners are responsible to compile their partner level progress reports and submit to the territorially competent FLC. Preparation of their partner level progress reports will be facilitated by the EPSF. After verification of the expenditures of the Beneficiaries and the Light Partners the FLC shall issue a Declaration on Verification of Expenditure (DoVE) that are to be delivered to the LB who shall prepare the project level Progress Report with the Application for Reimbursement and submit it to the JS.

### 3. Eligibility of Light Partner applicants

#### 3.1. Legal status

Light Partner should fall into the category of **small and medium-sized enterprises (SMEs)** stipulated in 651/2014/EU Regulation, Annex 1.

In Hungary SMEs are considered enterprises falling under the criteria stipulated under § 3 of the Act on Support for Growth of Small and Medium Enterprises (2004. évi XXXIV. törvény a kis- és középvállalkozásokról, fejlődésük támogatásáról). For Croatia SMEs are defined by the Article 2 of the Act on Incentives for the Development of Small Economy (Zakon o poticanju razvoja malog gospodarstva – NN 29/02, 63/07, 53/12, 56/13). According to these regulations medium, small and micro enterprises may all be beneficiaries of the Scheme.

**Owner interweaves should be excluded among Light Partners of each Light Project.** This means that Light Partners cooperating under a single Light Project should be autonomous enterprises from each other, stipulated under 651/2014/EU Regulation, Annex 1, Article 3. Partner or linked enterprises cannot be granted under a single Light Project.

#### 3.2. Geographical location

**Each Light Partner should have its seat or branch registered and acting in the eligible programme area** (NUTS III level counties):

Hungarian side:

- Zala county (HU223);
- Somogy county (HU232);
- Baranya county (HU231).

Croatian side:

- Međimurska county (HR046);
- Koprivničko-križevačka county (HR 045);
- Virovitičko-podravska county (HR 048);
- Osječko-baranjska county (HR 04B);
- Varaždinska county (HR 044);
- Bjelovarsko-bilogorska county (HR 047);
- Požeško-slavonska county (HR 049);
- Vukovarsko-srijemska county (HR 04C).



Figure 2: The eligible programme area.

Light Project activities have to be implemented in the eligible programme area listed above.

Light Beneficiary should have its seat or branch existing in the eligible programme area for at least one year counted from the date of submission of the Light Project Proposal (examined by company registry document).

### 3.3. Professional and financial background

Basic eligibility criteria for Light Partners are as follows (examined by company annual accounts):

- Light Partner or its owner company having more than 50% of ownership rights over the Light Partner or its linked enterprise through a natural person having **at least one closed business year**;
- Light Partner or its owner company having more than 50% of ownership rights over the Light Partner or its linked enterprise through a natural person employed **at least one employee** in its last closed business year;
- Light Partner's **equity is positive** for the last closed business year.

Light Partners need to comply with the following set of criteria related to their professional and financial background:

- Light Partners have to take direct responsibility for the preparation and management of their Light Project part both in professional and financial point of view and may not act as intermediaries.
- Light Partners must be experienced and able to demonstrate their capacity to manage their share of activities in the Light Project.
- Light Partners must prove their financial and administrative capacity to manage their share of the Light Project (ensuring pre-financing and own contribution).

### 3.4. Partnership requirements

**Light Projects should consist of at least 2 cooperating Light Partners; maximum number of Light Partners in one Light Project is 4.**

Each Light Project should consist of **at least one Light Partner from each side of the border**:

- at least one Light Partner should have its seat or its branch and should operate in the Hungarian programme area (in one of the following counties: Baranya, Somogy, Zala),
- at least one Light Partner should have its seat or its branch and should operate in Croatian programme area (in one of the following counties: Bjelovar-Bilogora, Koprivnica-Križevci, Međimurje, Osijek-Baranja, Požega-Slavonia, Varaždin, Virovitica-Podravina, Vukovar-Srijem).

By signing the Certification sheet of the Light Project Proposal form, Light Partners make a statement on the partnership in the Light Project. After selection of the Light Project for granting by the Selection Board, in order to exactly clarify the roles and responsibilities on level of the Light Project, the B Light Partnership Agreement shall be annexed by a Partnership Agreement Addendum signed by the LB and the Light Partners, including the commonly defined Light Project level indicators and the breakdown of indicators by Light Partners.

Like regular cross-border cooperation project partnerships, partnership of each Light Project should be balanced with a rational and efficient division of tasks and responsibilities among Light Partners. A Light Project partnership shall be composed of Light Partners that may be linked professionally to the Light Project and that

may have significant contribution and impact within the partnership. For sake of an operable and effective partnership, it must aggregate partners with common needs and objectives, while specific knowledge and expertise have to be ensured throughout.

### 3.5. Exclusion criteria

All potential Light Partners shall prove their professional and financial liability by not falling under any of the cases presented below. In order to ensure the fulfilment of the financial commitments, Light Partners cannot receive funding if one or more of the following cases apply to them:

- **Enterprises active** in the following sectors (gaining more than 50% of their annual turnover from these sectors in their past closed business year) are excluded:
  - **NACE code<sup>1</sup> A – Agriculture, forestry and fishing (01 –03).**
- Light Projects containing **development of the following activities**:
  - **fishery and aquaculture,**
  - primary production, processing and marketing of **agricultural products** listed in Annex I to the Treaty (see *Annex I of Guidelines for Light Partner Applicants*),
  - the establishment and operation of a **distribution network** towards third countries or Member States;
- Eligible activities of Light Project business cooperation do not belong to the NACE codes representing the target economic sectors of B Light Scheme (see Chapter 5.1.);
- Their business is in difficult situation (according to Regulation 800/2008/EK);
- They are bankrupt, being wound up, liquidated or having their affairs administered by the courts;
- They have entered into an agreement with creditors;
- They have suspended business activities;
- They are subject of proceedings concerning those matters, or are in any analogous situation arising from a similar procedure provided for in national legislation or regulations;
- They do not have valid registration to pursue their activities or they have been convicted of an offence concerning their professional conduct by a judgement which has the force of 'res iudicata', further they have been guilty of grave professional misconduct proven by any means which the MA/NA can justify;
- They have not fulfilled their obligations relating to the payment of social security contributions or the payment of taxes in accordance with the national legal provisions;

---

<sup>1</sup> See: NACE Rev. 2 Statistical classification of economic activities in the European Community, Eurostat, European Communities, 2008.

- They have been the subject of a judgement which has the force of 'res iudicata' for fraud, for corruption, for severe breach of contract in connection to obligations stemming from public procurement rules or from rules governing the use of Community funding or national subsidies, for involvement in a criminal organisation or for any other illegal activity detrimental to the Community's financial interests;
- They are subject to a conflict of interests connected to their participation in the present B Light Scheme;
- They are guilty of misrepresentation in supplying the information required by the LB/MA/NA as a condition of participation in the Scheme or in failing to supply information;
- They have attempted to obtain confidential information or to influence the Selection Board during the evaluation process of their Light Project Proposal.

By signing the Certification sheet of the Light Project Proposal form, Light Partners express they do not fall under any of the above written exclusion criteria.

---

<sup>1</sup> See: NACE Rev. 2 Statistical classification of economic activities in the European Community, Eurostat, European Communities, 2008

## 4. State aid rules

As the implementation of the B Light Scheme offers state support to undertakings, the Community competition rules for state aid must be fully respected. **All aids to undertakings under B Light Scheme will be granted as de minimis aid.**

EU and state contribution (both in kind and financial) provided by the B Light Scheme to Light Partners will be granted solely under the de minimis rule, according to Commission Regulation (EU) No 1407/2013 of 18 December 2013 on the application of Articles 107 and 108 of the TFEU to de minimis aid (Regulation). Titles under the General Block Exemption Regulation (GBER) will not be applied.

Besides the grant received by the Light Partners, free-of-charge assistance provided by the EPSF (both in the phase of developing the Light Project Proposal and during the Light Project implementation) is also considered as state aid and recorded as de minimis in a total amount of approx. EUR 5,000 per Light Partner (amount to be specified by public procurement). Although recipient of the state aid in connection with the EPSF is the Light Partner, assistance of the EPSF is contracted and financed by the LB HAMAG-BICRO.

According to the above-mentioned state aids received by Light Partners, the following declarations for state aid should be issued and should be sent during the online application process for each of the Light Partners together with other application forms which will be subsequently submitted to the JS. Every supported Light Beneficiary signs an agreement with LB HAMAG-BICRO on receiving EPSF services before the beginning of EPSF activities.

- de minimis self-declaration for receiving project management assistance of EPSF (after contracting);
- de minimis self-declaration for receiving funds from B Light Scheme for implementation of their eligible activities (after contracting).

The total de minimis aid granted to each Light Partner shall not exceed EUR 200,000 per Member State over the present and the previous two fiscal years. This threshold for each Light Partner exists separately for the two Member States, meaning that the same Light Partner can be granted a de minimis aid of maximum EUR 200,000 in Croatia plus a de minimis aid of maximum EUR 200,000 in Hungary (i.e. the de minimis aid received in different Member States are not to be cumulated – see Figure 3).

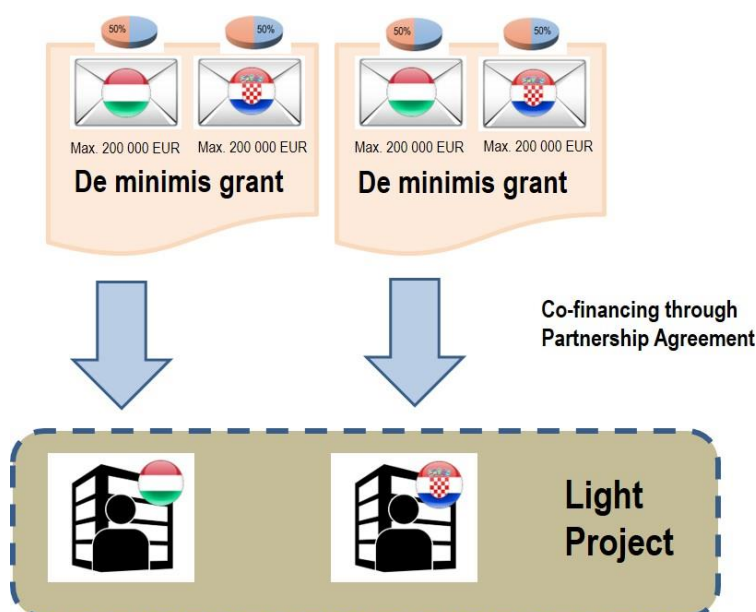

Figure 3: Composition of de minimis grant for Light Projects.



The linked enterprises with overlapping ownership structure are considered as one single enterprise according to Article 2 of the De minimis regulation, therefore the de minimis aid received by these Light Partners must be cumulated and the EUR 200,000 threshold must be respected for the cumulated amount. For details, please consult Article 2.2 of the Regulation.

Each Light Partner shall declare the total amount of de minimis aid granted to the Light Partner and its linked enterprises in the present and the previous two fiscal years in Hungary and Croatia, using the "Declaration on the de minimis aid for Light Partners". This declaration must be filled in, signed and submitted by the Light Partners once again as annex to their Light Project Proposal as grant received from B Light Scheme plus free-of-charge assistance provided by the EPSF during the Light Project implementation are also considered as state aid and recorded as de minimis.

This amount will be deducted from the EUR 200,000 threshold to define the maximum aid grantable to the Light Partner.

When defining the granting Member State for the de minimis aid under the B Light Scheme, the proportional approach will be applied. This means that the aid granted to each Light Partner (including both direct financial support and in kind free-of-charge services of EPSF) will be divided 50-50% between aid granted by Croatia and aid granted by Hungary. From the perspective of the Light Partner, it means that half of the received grant shall be deducted from its Hungarian de minimis threshold, and the other half shall be deducted from its Croatian de minimis threshold. This also means that under B Light Scheme no Light Partner may receive grant (including both financial and in kind) higher than the double value of the lower sum of the remaining amounts of its de minimis thresholds in the two countries.

The aid grantor shall inform the Light Partner about the prospective amount of the aid (expressed as gross grant equivalent) and of its de minimis character, and the Member State granting the aid, making express reference to Commission Regulation (EU) No 1407/2013 and citing its title and publication reference in the Official Journal of the EU. As part of the grant decision, the grantor (the Managing Authority in case of the financial support, or the HAMAG BICRO in case of the free of charge EPSF services) must give detailed information on the de minimis aid granted under the B Light scheme using the "Information sheet on the de minimis aid granted under the B Light Scheme". In case of the financial support, the Managing Authority will give the information on the de-minimis aid, but it does not affect the fact that the grant is given proportionate by the two Member States.

Records regarding de minimis aid shall be maintained for 10 years from the date on which it was granted, and such invitation of the granter the Light Partner is obliged to present all the documents. On request of the EC information shall be provided on de minimis aid within 20 workdays.

As B Light Scheme provides de minimis grant to SMEs, Light Projects containing development of the following activities are excluded:

- fishery and aquaculture,
- primary production, processing and marketing of agricultural products listed in Annex I to the Treaty (see Annex I of Implementation Manual),
- the establishment and operation of a distribution network towards third countries or Member States.

## 5. Eligibility of activities of Light Partners

### 5.1. Eligible activities

Eligible activities of **Light Project business cooperation** should belong to the following NACE codes<sup>2</sup> representing the target economic sectors of B Light Scheme:

C – Manufacturing (10 - 33);

D – Electricity, gas, steam and air conditioning supply (35);

E – Water supply; sewerage; waste management and remediation activities (36 - 39);

F – Construction (41 - 43);

G – Wholesale and retail trade, repair of motor vehicles and motorcycles – only one of the Light Partners can be granted to implement these types of activities within a single Light Project (45 - 47);

H – Transportation and storage (49 - 53);

I – Accommodation and food service activities – excluding extension and quality improvement of accommodation capacities, focusing on quality service development to be stipulated on call level (55 - 56);

J – Information and communication (58 - 63);

M – Professional, scientific and technical activities (69 - 75);

N – Administrative and support service activities, only the following activities:

- Employment activities (78),
- Travel agency, tour operator reservation service and related activities (79),
- Security and investigation activities (80);

P – Education (85);

Q – Human health and social work activities (86 - 88);

R – Arts, entertainment and recreation, only the following activities:

- Creative, arts and entertainment activities (90),
- Libraries, archives, museums and other cultural activities (91),
- Sports activities and amusement and recreation activities (93).

All eligible activities of each Light Partner should belong to any of the above listed NACE codes. Activities outside these NACE codes are ineligible.

---

<sup>2</sup> See: NACE Rev. 2 Statistical classification of economic activities in the European Community, Eurostat, European Communities, 2008.

Independently eligible activities:

- Development of new technology, service or product.
- Purchase of equipment for the sake of joint technology, service and product development.
- Purchase of equipment for the sake of moving materials, packaging and storing in the phase of joint technology, service and product development (purchase of vehicles is prohibited).
- ICT development: purchase and installation of new hardware and software equipment (with the exception of general office use).
- Activities for entering new markets of jointly developed technology, service and product:
  - Appearance on events, fairs, business meetings, international project development workshops organised outside programme area;
  - Organisation of business seminars, workshops, conferences;
  - International market surveys;
  - Development or upgrading of marketing tools and materials in foreign language (design, layout, elaboration);
  - Marketing actions targeting markets outside the programme area.
- External expertise for the sake of developing joint technology, service and product.

Eligible activities to be combined with independently eligible activities:

- Investment in basic infrastructure development and construction, enlarging, restructuring, refurbishment or modernisation of building for the sake of operating equipment for joint technology, service and product development.
- Purchase of equipment for general office use.
- Purchase of intangible fixed assets: purchase of patent and other kind of intangible assets (licence, protection), purchase of utilisation rights for intangible assets.
- Organisation of trainings, seminars for improving knowledge on developing joint technology, service and product.
- Employment of new and existing employees for the sake of developing joint technology, service and product.
- Light Project administration and management: organisation of Light Partner meetings, collection of documents of expenditure, maintenance of files, public procurement activities on level of the Light Partners (Light Project management activities beyond the responsibilities of EPSF, see Chapter 9.3.).

Purchase of second hand equipment is not eligible in general, except the following conditions are fulfilled: (1) no other assistance has been received for it from the ESI Funds; (2) its price does not exceed the generally accepted price on the market in question; (3) it has the technical characteristics necessary for the operation and complies with applicable norms and standards; (4) it is not feasible to substitute with new equipment (e.g. due to its speciality, to its age or cultural value or to the price difference).

In case of Light Projects with works project elements, Light Partners for submission of the Light Project Proposals should have available construction plans ready to be submitted to the relevant authority in order to acquire the building permit, if the activity is subject to building permit. Detailed description for works elements are detailed in Chapter 10.

Important to point out that developed building or infrastructure can't be sold and must be kept free of all liens and claims for 2 years.

## 5.2. Eligible levels of cooperation

Minimum cooperation level requirement within a Light Project is a value-added cross-border joint technology, service and product development by the cooperating Light Partners operating on different sides of the border for setting up cross-border supplier networks and/or for jointly engaging into new market.

Reflecting on the minimum required cooperation level, **two result indicators should be met by each Light Project proving their value-added cooperation:**

- Documentary evidence of **signed contractual business agreement with third parties for selling** the commonly developed new or upgraded product, technology or service by either or all of Light Partners within the sustainability period of their Light Project (2 years after completion of their Light Project), proven by signed business agreement / agreements.
- **Reaching the minimum value of selling** of commonly developed new or upgraded product, technology or service by either or all of Light Partners, required minimum value is **20% of the total grants allocated** to the Light Project within the sustainability period of their Light Project (2 years after completion of their Light Project), proven by trial balance of the Light Partners.

Reaching the following additional eligible levels of cooperation means more valuable Light Project:

- Previous record of development activities and cross-border business cooperations of the Light Partners;
- Human capacities of Light Partners and their competences in relation to the Light Project content;
- Innovative character of product, technology or service development;
- Business potential of product, technology or service development;
- Methodology of project implementation;
- Relevance and preparedness of Light Project budget.

Level of cooperation is measured following the marketing concept of the Ansoff matrix<sup>3</sup>, determining the Light Project's product and market growth, thus giving indication to the Light Project's contribution to gross value-added which is the main result indicator of the B Light Scheme (see Figure 4).

---

<sup>3</sup> Ansoff, I.: Strategies for Diversification, Harvard Business Review, Vol. 35 Issue 5, Sep-Oct 1957, pp. 113-124. <http://www.ansoffmatrix.com/>

		Product	
		Present	New
Market	Present	<b>MARKET PENETRATION</b> Placing an existing product to an existing market – NOT ELIGIBLE	<b>PRODUCT DEVELOPMENT</b> Introduction of a new product to an existing market
	New	<b>MARKET DEVELOPMENT</b> Finding a new market to an existing product	<b>DIVERSIFICATION</b> Development of a new product to a new market

Figure 4: Application of the Ansoff matrix in measuring level of cooperation of Light Projects.

According to the Ansoff matrix the following levels of business cooperation intensity may be identified concerning the Light Projects (from the lowest to the highest intensity):

**PENETRATION:** Placing existing product, technology or service to existing markets of Light Partners, without entering into each other's market or third markets. Provision of only promotional intervention that may result a better knowledge about the product, technology or service on the existing markets. – This is **INELIGIBLE** for granting from B Light Scheme.

**MARKET DEVELOPMENT:** Finding a new market to an existing product: an already developed product, technology or service will be placed on a new market (the partner country's market or a third one), which can be made possible through this cooperation. In this case one of the Light Partners is the owner of the product, the other one provides an access to the new market (in its own or third country). – This is **CONDITIONALLY ELIGIBLE** if entering the new market does not mean parallel reduction of market presence in the Light Partner's existing markets but increase in total selling.

**PRODUCT DEVELOPMENT:** Introduction of a new product to an existing market: a new product, technology or service will be developed to a market where one of the Light Partners are already present. In this case both Light Partners are co-developers of the product that will be placed on one of their existing markets. In this type of cooperation the product know-how represent the added value of cooperation. This is **ELIGIBLE** for granting from B Light Scheme.

**DIVERSIFICATION:** Development of a new product to a new market: both the developed product, technology or service and the gained market are new. This represents the most advanced level of cooperation that may involve several modality options: one (or more) of the Light Partners do the product development, other Light Partner(s) give the access to the new market which may be in the partner countries or in third countries. This is the level of cooperation intensity where cooperation of more than two Light Partners may be necessary. This is the **MOST PREFEREABLY ELIGIBLE** for granting from the B Light Scheme.

## 6. Co-financing of Light Projects

### 6.1. Type of co-financing

EU contribution to Light Partners financed from B Light project is non-repayable grant.

### 6.2. Co-financing rate

Payment of the EU and national co-financing takes place upon approval of the Scheme's periodical progress reports and final report. Payment is carried out to the bank account of LB HAMAG-BICRO. The LB is obliged to transfer the appropriate sum of co-financing to the Beneficiaries and the Light Partners.

**A maximum of 75% of the total eligible expenditure can be requested as grant from the B Light Scheme, the rest shall be covered as own contribution of Light Partners.**

### 6.3. Own contribution

**Each Light Partner should provide a minimum of 25% of the total eligible expenditure as own contribution for implementation of the Light Project.**

Own resources can be composed of any kind of financial resources (e.g. money on bank account, bank loan) with the exception of grants requested from the European Union or from National co-financing resources.

### 6.4. Light Project size

**Minimum and maximum size of Light Projects per Light Partner in the 4<sup>th</sup> Call for Proposal:**

	<b>Total eligible costs (100%)</b>	<b>Maximum ERDF co-financing (75%)</b>
Minimum per Light Partner	<b>EUR 40,000</b>	EUR 30,000
Maximum per Light Partner	<b>EUR 160,000</b>	EUR 120,000

**Total costs of cooperation activities of Light Partners may exceed EUR 160,000, but in this case all costs above this threshold are regarded as costs outside the Light Project's eligible cost.**

**As VAT is not eligible, all costs should be budgeted without VAT.**

As the funded bodies are SMEs, implemented activities being considered as state aid relevant, the maximum grant will be calculated applying the de minimis rule, where the maximum grant for three consecutive years shall not go beyond EUR 200,000 per Member State (see Chapter 4.).

## 7. Eligibility of costs of Light Partners

### 7.1. Preparation costs

Preparation costs represent a special eligible expenditure that is automatically granted to the Light Partners who successfully sign Partnership Agreement with the LB for implementation of their Light Project up to an amount of **total EUR 1,000 per Light Partner as a lump sum cost** related to the preparation of the Light Project Proposals.

Any difference between the granted lump sums and the costs occurred in reality for these activities is neither checked nor further monitored by the Cooperation Programme implementing structure. B Lights do not need to document that the expenditure has been incurred and paid or that the expenditure corresponds to reality.

### 7.2. Staff costs

The costs of staff are expenditures incurred connected to the personnel involved in the implementation of the Light Project on behalf of the Light Partners. The staff involved in project implementation with a valid contract can work full-time or part-time and can do administrative and/or professional tasks. Staff costs shall be clearly connected to the project and its activities.

Staff costs for Light Partners are eligible for both existing and newly hired employees, employed for the purposes of the implementation of the Light Project. Light Partners may choose in their Light Project Proposal to apply either standard scales of unit costs or calculation on real cost basis. This choice shall remain unchanged during implementation of the Light Project part.

a) Standard scales of unit costs

In case of **standard scales of unit costs** monthly staff cost rates are defined upon qualification requirements.

Category	Qualification requirements	Monthly rate (gross amounts + social security charges)
manager / engineer / product developer / marketing expert	High education degree (VSS – BA, BSc or higher) with minimum 3 years of experience.	EUR 1,700
physical and administrative workforce	Secondary education in the relevant physical and administrative field, with minimum 1 year of work experience.	EUR 800

If an employee is not employed full time, the unit cost shall be applied proportionally according to the full time equivalent (FTE) rate.

Light Partners are required to document and report the fact of employment, the position and the qualification of the employee according to the staff categories above, the FTE of the employment and the employment period. The eligible cost is then calculated as a multiplication of the relevant monthly staff unit cost, the FTE ratio and the number of months of the employment.

In case of applying standard scales of unit costs, any difference between the granted unit cost based amount and the costs occurred in reality for staff costs is neither checked nor further monitored by the Cooperation Programme implementing structure. Light Partners do not need to document that the expenditure has been incurred and paid or that the expenditure corresponds to reality.

b) Real cost

If **real cost** option is applied, the actually spent (paid) expenses are eligible, including the following:

- Salary payments related to the activities which the organisation would not carry out if the Light Project was not undertaken, fixed in an employment document (employment contract, an appointment decision or any other equivalent legal agreement which enables for the identification of the employment relationship with the Light Partner) or by legislation relating to responsibilities specified in the job description of the staff member concerned.
- Any other costs directly linked to salary payments incurred and paid by the employer (such as employment taxes and social security charges, including pensions), provided that they are:
  - fixed in an employment document or by legislation;
  - in accordance with the legislation referred to in the employment document and with standard practices in the country and/or institution where the individual staff member is working;
  - not recoverable by the employer.

With regard to payments to natural persons working for the Light Partner under a contract other than an employment/work contract (egyéni megbízás / ugovor o djelu) may be assimilated to salary payments, and such a contract is considered as an employment document. Such costs are eligible if all the following conditions are respected:

- the person works under the Light Partner's instructions and, unless otherwise agreed with the Light Partner, on the Light Partner's premises;
- the result of the work carried out belongs to the Light Partner, and
- the costs are not significantly different from those for personnel performing similar tasks under an employment contract with the Light Partner.

Principles to be applied for existing employees on real cost basis:

- Salaries, other payments and benefits are only eligible if foreseen in the legislation, company internal regulation, collective wage agreements or in a workers' council agreement and if they are in line with the employment policy of the Light Partner (ad hoc regulations applicable only to the project are not allowed).
- Unjustified ad-hoc salary increases or bonuses for Light Project purposes are not eligible.

---

<sup>4</sup> According to Regulation (EC) No 883/2004 of the European Parliament and of the Council.



- Where foreseen by the employment document, overtime is eligible, provided it is in conformity with the national legislation and the standard practice of the Light Partner, and if it is based on an appropriate time registration system. In case of part time employment, overtime shall be proportionally allocated to the Light Project.
- The adequacy of staff costs must always be ensured. When claimed staff costs are not adequate in quality and/or quantity to the realised Light Project deliverables and outputs as listed in the Light Project documentation, a flat rate correction may be applied following the principle of proportionality.
- Staff costs must be calculated individually for each staff member charged to the Light Project.

The staff can be allocated to work full time (100% of the working time is allocated to the Light Project) or part time for the Light Project. In both cases the planned ratio of working time has to be clearly indicated in the budget table, included in the relevant cost item of the given staff.

Staff costs of part-time employees have to be calculated using one of the following methods:

- part-time with a fixed percentage of time worked per month on the Light Project, with no obligation to establish a separate working time registration system;
- part-time with a flexible number of hours worked per month, in line with a number of hours varying from one month to the other worked on the Light Project, based on a time registration system covering 100% of the working time of the employee;
- on an hourly basis.

Supporting documents for calculating staff expenditure on a real cost basis:

- full list of project staff within the Light Partner's organisation, stating name of the employee, function in the project, percentage of work dedicated to the Light Project and total gross salary (has to be available from the first report of the Light Project);
- work contracts which permit the identification of the employment relationship between the Light Project staff and the Light Partner;
- a clear assignment (working contract / job description) providing information on the main tasks within the Light Project;
- payslips, proofs of payment (e.g. bank statements);
- calculation evidence for the determination of the hourly rates of the Light Project staff;
- timesheets (not applicable for part-time with fixed percentage of time worked on project) which prove the overall working time and the time spent on carrying out activities for the Light Project (name of the employee, date, time and detailed description of the activity) – the timesheet must be signed by the Light Project's assigned employee and by the employer.

**Staff costs in total are not allowed to amount more than 80% of the respective Light Partner's budget.**

If staff costs are included, **Curriculum Vitae (preferably Europass in English) of the relevant existing Light Project staff members have to be attached** to the Light Project Proposal.

### 7.3. Office and administrative expenditure

As regard to the eligibility of office and administrative expenditure, it is **automatically calculated as a flat rate of 15% of the staff costs**.

Office and administrative expenditure shall be limited to the following elements:

- Office rent;
- Insurance and taxes related to the buildings where the staff is located and to the equipment of the office (e.g. fire, theft insurances);
- Utilities (e.g. electricity, heating, water);
- Office supplies;
- General accounting provided inside the Light Partner organisation;
- Archives;
- Maintenance, cleaning and repairs;
- Security;
- IT systems (operating/administrative IT services of general nature, linked to the implementation of the Light Project);
- Communication (e.g. telephone, fax, internet, postal services, business cards);
- Bank charges for transnational financial transactions.

Cost items accounted under the office and administration cost category cannot be reimbursed under any other cost category.

Any difference between the granted flat rate based sums and the costs occurred in reality for these activities is neither checked nor further monitored by the Cooperation Programme implementing structure. Light Partners do not need to document that the office and administration expenditure has been incurred and paid or that the flat rate corresponds to the reality.

### 7.4. Travel and accommodation expenses

Travel and accommodation expenses of the staff – being employed by the Light Partners – involved in the implementation of the Light Project are **eligible costs on real cost basis** if they are incurred for performing tasks directly related to the Light Project activities.

Travel costs may include the following means of transportation:

- Travel costs: as a general rule for travelling, the most economical way of transportation has to be used:
  - Travelling by car – it is allowed to use a private or company car only if it is the most economical way of transportation and it is proven to be a time-saving solution.
  - Travelling by rail / bus / ship / plane – as a general rule the most economical and efficient way of transport should be used. No first or business class tickets are eligible.
  - Local travel fares (bus, underground, taxi etc.).
  - Insurance fees – to cover the costs of insurance for the whole trip.

- Accommodation and meal costs can be reimbursed if they are in a reasonable price range and if per diem does not cover them. Middle price range accommodation has to be used, 3-stars hotels are generally accepted within this category. The use of higher category accommodation has to be justified. Duration of the mission must be clearly in line with its purpose. Costs of longer duration are eligible only if it results savings made in the costs of transportation.
- Visa costs.
- Per diems (daily allowances) of the Light Project staff shall be defined by the employer. They must not exceed the rate set by the European Commission on the following link: [https://ec.europa.eu/europeaid/applicable-rates-diems-framework-ec-funded-external-aid-contracts-18032015\\_en](https://ec.europa.eu/europeaid/applicable-rates-diems-framework-ec-funded-external-aid-contracts-18032015_en).

Per diems can be paid to Light Project staff that travel abroad for the purpose of the Light Project. Per diems generally cover meal, accommodation and local travel expenses. In case of receiving per diem other subsistence costs are not eligible.

## 7.5. External expertise and services

Expenditure on external expertise and service costs are **eligible costs on real cost basis** including the following services and expertise provided by a public or private law body or a natural person other than the Light Partners' staff:

- Technical plans and permits: Light Project involving infrastructure and works where external expenditure related to preparation of necessary project documentation (meaning construction plans, detailed cost estimation, environmental documentation of the investment and feasibility study) and costs for obtaining the necessary permissions shall be budgeted under this budget line. Costs can also be eligible if they occur before the date of receipt of the Light Project Proposal form by the LB (submission of Light Project Proposal), but not earlier than 1 January 2014.
- Studies or surveys: evaluations, strategies, design plans, handbooks necessary for the cooperation of the Light Partners.
- Events, conferences, seminars, trainings, Light Project meetings – the budget line shall include all costs emerging related to a Light Project event, including fees of lecturers / performers / trainers / experts, as well as costs like interpretation, translation of documents, rental costs, technical background, catering, travel costs of members of the target group etc. Activities closely related to the organisation of events can be externalised separately based on the activity type as well (e.g. transportation, translation, rental activities etc.); travel and accommodation for external experts, speakers, chairpersons of meetings and service providers.
- Costs of supervisor of engineering, architect's site supervision: in case of Light Project with works components.
- Cost related to publicity, promotion and communication: IT systems and website development, modifications and updates; promotion, communication, publicity or information, participation in promotional events (e.g. registration fees).
- Other: intellectual property rights; provision of guarantees by a bank or other financial institution where required by EU- or national law; other specific expertise and services needed for the Light Project; rent of equipment.

- Services related to Light Project administration and management: collection of documents of expenditure, maintenance of files, public procurement activities on level of the Light Partners. Only Light Project management activities beyond the responsibilities of EPSF are eligible here (role of EPSF during Light Project management and reporting see Chapter 9.6.). **Light Project management services in total are not allowed to amount more than 5% of the respective Light Partner's budget.**

The 'external expertise and services' category covers costs paid on the basis of contracts or written agreements and against invoices or requests for reimbursement to external experts and service providers, sub-contracted to carry out certain tasks or activities directly linked to the implementation of the project.

## 7.6. Equipment

Purchase of equipment is eligible only if the items are essential and directly related to the implementation of the Light Project, and if they are listed in the approved Light Project budget.

All equipment shall be other than those covered by the expenditures of cost categories 'Office and administration' and 'Infrastructure and works' and are necessary and shall exclusively be used for Light Project implementation, having a clear contribution to the achievement of the Light Project's objectives.

Equipment shall be distinguished according to its purpose:

- Content-related / thematic equipment, directly linked to (or forming part of) the Light Project outputs or deliverables which will be used by Light Partners and target groups in line with the Light Project objectives. Thematic equipment may be also linked to the 'Investment and works' budget line. Purchase of the following types of equipment is **eligible costs on real cost basis**:
  - IT hardware and software (clear Light Project relevance is necessary);
  - Furniture and fittings;
  - Laboratory equipment;
  - Machines and instruments;
  - Tools or devices;
  - Other specific equipment needed for the Light Project.
- Equipment for general (office) use, such as computers, office furniture etc. which is used for the daily work of the project staff and which is not already included under 'Office and administration'. Eligible expenditure that is automatically granted to the selected Light Project for purchase of equipment for general office use is automatically granted to the Light Partners up to an amount of total **EUR 1,000 per Light Partner as a lump sum cost.**

Depreciation costs are not eligible, equipment for Light Project sustainability can be charged in its full amount to the Light Project.

Eligibility of costs for equipment is subject to the full respect of national public procurement rules, according to the thresholds, and for the type of entities as defined in the national law. For all equipment purchased, the relevant visibility and publicity requirements of the Programme must be respected.

**Expenditure of second hand equipment is eligible** if following conditions are all fulfilled:

- no other assistance has been received for it from the ESI Funds;
- its price does not exceed the generally accepted price on the market in question;
- it has the technical characteristics necessary for the operation and complies with applicable norms and standards;
- it is not feasible to substitute with new equipment (e.g. due to its speciality, to its age or cultural value or to the price difference).

## 7.7. Infrastructure and works

Infrastructure and works are **eligible costs on real cost basis** comprising the following activities:

- Construction of buildings, works and infrastructure – these costs comprise expenditure related to construction activities.
- Reconstruction, renovation of buildings, works and infrastructure – these costs comprise expenditure related to works needed for the alteration, reconstruction, expansion of a used building.
- Works expenditure shall be limited to elements listed in Annex II of Directive 2014/24/EU. Costs of feasibility studies, environmental impact assessments, architectural/engineering activities and any other expertise needed for the realisation of the infrastructure not comprised in the aforementioned Directive shall be allocated under the 'Staff' or 'External expertise and services' cost category (depending whether carried out internally by the staff of the Light Partners or with the support of external suppliers, respectively).
- The same logic applies for equipment forming part of infrastructure/works realised within the Light Project and shall be reported under the 'Equipment' budget line when it cannot be categorised under the 'Infrastructure and works' budget line due to Annex II of Directive 2014/24/EU.
- These costs are only considered eligible if they are directly linked to the Light Project and are proven to be essential for its effective implementation.
- Requirements concerning durability, including ownership and maintenance, as provided for in Article 71 of the CPR and further detailed in the programme publicity rules apply to infrastructure developments realised by the Light Project.

**Purchase of land is not eligible.**

Further eligibility rules to be considered:

- Construction shall be in accordance with all national legal measures and codes (construction, hygienic and safety) in force.
- The contractor cannot be a Lead Beneficiary, Beneficiary or Light Partner in the Light Project.
- The selection of the external suppliers shall comply with the applicable regulations on public procurement in force.
- The relevant publicity requirements of the Programme must be respected.

- Only expenditure of the infrastructure and works explicitly described in the approved Light Project can be verified.
- Contractual advances in accordance with normal commercial law and practice, stipulated in a contract between the Light Partner and the provider, supported by receipted invoices (e.g. advance payment for the company selected for construction works) are eligible but dependent on later confirmation that infrastructure and works have been properly and timely executed.

Indicative list of expected supporting documents for validation purposes:

- Documents on the selection of the contractors are available (documents of the public procurement);
- The contract laying down the works for the small scale investment in the framework of the Light Project;
- The evidence of the infrastructure and works (e.g. documentation of the works as requested by the respective regulations and the rules of the public procurement);
- Invoices (advance payment certificates / interim payment certificates / final payment certificate);
- Proof of payment;
- Photo documentation of the 'Infrastructure and works' type of activity (with the obligatory information and publicity elements of the Programme visible);
- Permits (environmental permit, usage permit etc.).

**Detailed description – including the documentation needed – of financing infrastructure and works elements of Light Projects is given in Chapter 10.**

## 7.8. Ineligible expenditure

The following costs are ineligible for Light Partners:

- any service costs implemented in each Light Partner's own implementation, any purchase of equipment produced or distributed by each Light Partner;
- any works, equipment or service costs purchased from partner or linked enterprises of any Light Partners according to 651/2014/EU Regulation or from enterprises in which any Light Partner's executive officers or owners or their close relatives act as executive officers or owners;
- any costs incurred before submission of the Light Project – with exception of technical plans and permits related to Light Project involving infrastructure and works; As a general rule, based on Article 65 (2) of the CPR, only expenditure shall be eligible for EU contribution which has been incurred by a Beneficiary and paid between 1 January 2014 and 31 December 2023.
- value added tax (VAT);
- purchase of existing buildings;
- purchase of land;
- fines, financial penalties and expenditure on legal disputes and litigation;
- second hand equipment in general,
  - except the following conditions are simultaneously fulfilled: (1) no other assistance has been received for it from the ESI Funds; (2) its price does not exceed the generally accepted price on the market in question; (3) it has the technical characteristics necessary for the operation and complies with applicable norms and standards; (4) it is not feasible to substitute with new equipment (e.g. due to its speciality, to its age or cultural value or to the price difference);

- bank charges, except
  - the charges for transnational financial transactions;
- costs related to fluctuation of foreign exchange rate (including e.g. conversion costs, charges and exchange losses associated with any of the component specific EUR accounts etc);
- costs of guarantees and similar charges;
- contributions in kind (e.g. free use of rooms, equipment or other facilities, unpaid voluntary work, generally any contribution without money flow);
- operating and general costs (overheads), with the exception of costs related to office and administrative expenditure laid down in Chapter 7.3.;
- interest on debt;
- debts and provisions for losses or debts;
- commissions and dividends, profit payments;
- purchase of business shares and stock exchange shares;
- unpaid invoice amounts or undrawn reduction of the price (cash discount, discount);
- subcontracted activities increasing the cost of the Light Project without adding proportionate value to it;
- any expenditures not directly related to the Light Project and associated with the Light Partners of the Light Project;
- any forms of double funding of expenditures: expenditure which is already supported by EU or other national or international funds, subsidies.

The list of ineligible expenditures is not exhaustive; expenses not included in the list above are not automatically eligible. Without prejudice to the provisions of the EU regulations concerned, further rules on eligibility of expenditure may be laid down by the Member States of the Programme.

## 8. Evaluation and selection of Light Projects

### 8.1. Light Project Proposals

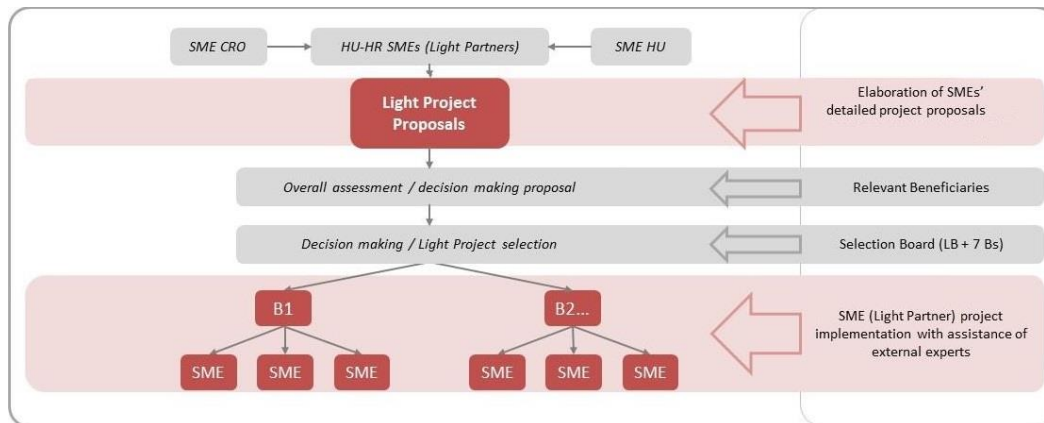

Figure 5: Light Project selection system of B Light Scheme.

Detailed elaboration of Light Project Proposals is also coordinated by the Lead Beneficiary and the Beneficiaries by the following project generation activities:

- Launching the open Call for Light Project Proposals.
- Beneficiary's representatives will help the elaboration of the Light Project Proposals to the cooperating SMEs
- Submission of the Light Project Proposals should take place until the deadline defined in the Call for Light Project Proposals through the online B Light Platform operated by the Lead Beneficiary HAMAG- BICRO.

Main content elements of Light Project Proposal (see Light Project Proposal form):

- main data of Light Project (title, duration, location);
- administrative and fiscal data of Light Partners;
- Introduction of Light Partners: their former and present activities, main markets of their products and services, export-import relations, human capacities;
- description of Light Project: description of joint product, service or technology, competences of selling, places and predicted value of selling, business potential, innovative character, methodological approach, risk management, consistency and synergy;
- list of activities by Light Partners and timeframe of activities;
- definition of Light Project indicators: contribution to programme level result indicator of increase of gross value added of Light Partners within the sustainability period; specific indicators: number of signed contractual business agreements with third parties to be contracted in the sustainability period, number of counties involved in SME cooperation, target value of selling of commonly developed new or upgraded product, service or technology by either or all of Light Partners within the sustainability period; general and horizontal indicators;
- detailed budget and description of listed activities by Light Partners;
- sources of funding by Light Partners;
- payment forecast by reporting periods and by Light Partners;
- location of works activities and required permits;
- information and publicity activities;
- supplementary documentation in Annexes (CVs of Light Project staff, documentation related to works activities – see Chapter 10).

Light Project Proposal is prepared jointly by the cooperating SMEs. **Required language of Light Project**



**Proposal is English.**

Submission of the Light Project Proposal should take place by any of the involved Light Partners through the B Light Platform operated by the Lead Beneficiary HAMAG-BICRO (for web link of B Light Platform see Call for Light Project Proposals) through upload of the Light Project Proposal form in filled-in MS Excel version, the signed scanned version of the certification sheet and all the needed supplementary documents.

**Submission of Light Project proposals should take place after launching the Call for Light Project Proposals with submission deadlines defined by the Application Pack.**

- Evaluation and decision on Light Projects Proposals has the following process:
- Light Project Proposals are jointly evaluated by the territorially competent SME development agencies (Beneficiaries): territorially competent SME development agencies of all Light Partners judge administrative and eligibility compliance of the submitted Light Project Proposal (administrative and eligibility criteria see Annex II).
- Territorially competent SME development agencies (Beneficiaries) either reject or approve the proposal for further content-based evaluation. For incomplete Light Project Proposals Light Partner applicants will be requested to deliver completion of missing documents concerning administrative compliance until a given deadline (completion is possible if the given administrative criterion is allowed to be completed, see Annex II).
- If content and/or cost of any budget items of the Light Project needs to be further specified, territorially competent SME development agencies may ask Light Partner applicants for clarification.
- After the administrative and eligibility compliance has been checked, three different scores (from the LB, from the JS and from two territorially independent main Beneficiaries jointly) will be awarded to each Light Project Proposal, using the same evaluation grid (see Chapter 8.3.).
- The final score for a single LPP will be the mathematical average of the three scores awarded by the different evaluators. (The joint score awarded by the two Beneficiaries that are involved shall be the mathematical average of their own two scores.)
- After finishing the content-wise evaluation, within 60 days after submission deadline of Light Project Proposals a Selection Board session should be organised.
- If one or more Light Partners withdraw from the partnership at any point of the application process, the LPP will be ineligible for funding. In this case, Light Project proposal that is next on the Rank List of evaluated proposals should be recommended for funding.
- Based on the decision of the Selection Board the Lead Beneficiary should sign Partnership Agreement Addendum with Light Partners of the granted Light Project.

## 8.2. Evaluation grids

**Evaluation grid for selection of Light Project Proposals:**

Rejection criterion	
Light Project focuses on either market development or product development or both (diversification), according to business cooperation intensity levels stipulated by Ansoff matrix under Chapter 5.2. Placing existing product, technology or service to existing markets of Light Partners, without entering into each other's market or third markets (penetration) is INELIGIBLE for granting from B Light Scheme.	<b>Yes/No</b>

Light Project Proposal is scored by the evaluation criteria if it meets the above rejection criterion, otherwise should be rejected. If evaluator chooses 'No' on the rejection criterion, a detailed explanation should be provided.

<b>Evaluation criteria</b>	<b>Maximum score</b>
<b>Financial background of Light Partners</b>	<b>10</b>
At least one of Light Partners has instable financial background: close to zero equity or low liquidity ratio (below 0,5).	0
All Light Partners have stable financial background (amount of equity and liquidity ratio are all at acceptable level), but at least one of Light Partners has relatively low annual turnover in comparison to the grants requested (less than half of grants requested).	5
All Light Partners have stable financial background (amount of equity and liquidity ratio are all at acceptable level) and relatively suitable level of annual turnover (more than half of grants requested).	10
<b>Previous international business activities of Light Partners</b>	<b>5</b>
None of the Light Partners have international business cooperation, their operation focuses on domestic markets.	0
At least one of the Light Partners have export-import business cooperation.	3
All Light Partners have existing export-import business cooperation.	5
<b>Human capacities</b>	<b>5</b>
Staff of Light Partners does not have selling and marketing experience.	0
Staff of at least one of Light Partners already took part in entering the market of developed product, service or technology.	3
Staff of all Light Partners have strong competences in management of selling and marketing of developed product, service or technology.	5
<b>The product</b>	<b>10</b>
Jointly developed product, service or technology does not have significant new content.	0
Product, service or technology is planned to be developed on basis of new combination of an existing product, service or technology which means limited value added to the market.	5
Jointly developed product, service or technology generates significant novelty on the market in international manner.	10
<b>The market</b>	<b>10</b>
Market entrance of developed product, service or technology is not sufficiently established, market demand is uncertain.	0
Market entrance of developed product, service or technology is established and realistic, market demand seems to be significant on the market. Developed product, service or technology is planned to be sold mainly within the programme area.	7
Market entrance of developed product, service or technology is established and realistic, market demand seems to be significant on the market. Developed product, service or technology is planned to be sold mainly outside the programme area.	10
<b>Light Project activities</b>	<b>5</b>
Some of the planned activities show inconsistency with the subject and market of Light Project cooperation, these activities seem to be not in harmony with the product development and market selling aims of the Light Project.	0
Independently eligible activities described are in line with Light Project content, however there are some activities seem to be unnecessary in the Light Project.	3
All activities described are in line with Light Project content, the planned activities are all needed for successful accomplishment of product development and marketing.	5

<b>Evaluation criteria</b>	<b>Maximum score</b>
<b>Places and value of selling</b>	<b>10</b>
Places of selling are not sufficiently described, predicted value of selling is uncertain.	0
Places of selling are sufficiently segmented to specific markets, but predicted value of selling is uncertain.	5
Both places of selling is well described and predicted value of selling is realistic to achieve 20% of requested EU-co-financing 2 years after completion of the Light Project.	10
<b>Innovative character</b>	<b>10</b>
Value-added of innovation of product, service or technology development is only relevant for the cooperating companies (Light Partners).	0
Innovation of product, service or technology development is relevant on local or county level.	5
Innovation of product, service or technology development is relevant for the whole programme area of B Light Scheme	10
<b>Methodology of cooperation</b>	<b>4</b>
Cooperation activities between Light Partners during Light Project implementation is not sufficiently elaborated, Light Project mainly contains partner-oriented rather than cooperation oriented activities.	0
Cooperation activities between Light Partners during Light Project implementation is well elaborated also from content-related and organisation-related aspects, Light Project mainly contains activities based on cooperation of Light Partners.	4
<b>Risk management</b>	<b>3</b>
Possible risks of Light Project implementation are neglected and less taken into account.	0
Risk factors are well described and evaluated, measures for handling these risks are also defined.	3
<b>Consistency and synergy</b>	<b>3</b>
Contribution to EU horizontal principles are neglected and not taken into account.	0
Contribution to EU horizontal principles are well described and impact of Light Project to these principles are sufficiently described.	3
<b>Description of activities</b>	<b>5</b>
Activities of Light Project are not sufficiently described in details, there are unclear activities.	0
All activities are well elaborated in details containing clearly defined actions.	5
<b>Budget and timing of activities</b>	<b>10</b>
Timing of some Light Project activities are not properly defined and also there are over- or underestimated budget lines.	0
Timing of all Light Project activities are properly defined and realistic, but there are over- or underestimated budget lines.	5
Both timing of all Light Project activities are properly defined and all Light Project activities are budgeted realistically with no over- or underestimation.	10

<b>Evaluation criteria</b>	<b>Maximum score</b>
<b>Definition of indicators</b>	<b>10</b>
Definition of all types of indicators is rather weak: contribution to programme level result indicator is unclear, definition of specific indicators are at the lowest possible level, general and horizontal indicators are at low level.	0
At least one type of indicators is defined at rather low level (either contribution to programme level result indicator or definition of specific indicators or definition of general and horizontal indicators).	5
Definition of all types of indicators is at sufficient and realistic level: contribution to programme level result indicator is well described, definition of specific indicators are at acceptable level compared to size of the Light Project, general and horizontal indicators are at sufficient level.	10
<b>TOTAL SCORE</b>	<b>100</b>

**For evaluation of Light Project Proposals, a total of 100 points can be achieved**

**Light Project Proposal is ineligible for granting if total score of Light Project Proposal is under 60 points.**

### **8.3. Selection Board**

The Scheme's main decision making body is the Selection Board (SB). The SB is responsible to make selection of the granted Light Project proposals. The SB is composed of 8 members, delegated by the LB and the 7 Bs.

Decisions in the SB are made with majority voting, however for selection of the Light Project proposals need the unanimous positive decision of the territorially competent SB members (i.e. the territorially competent SME development agencies). The LB has block voting rights in terms of administrative and financial issues. From programme level bodies, the MA, NA and the JS are invited as non-voting members, however the MA shall have the right of veto if a decision made by the SB would threaten the overall due performance of the cross-border cooperation programme.

### **8.4. Contracting**

Regarding contracting, it needs to be emphasized that the whole B Light Scheme is one project in the Cooperation Programme's administrative and legal logic. Therefore one Subsidy Contract has been signed with the partnership as a whole, at the time when the B Light Scheme project was approved by the MC. The entering of Light Partners in the Scheme does not change the Subsidy Contract, only the Partnership Agreement between the partners, through the Addenda of Light Partners.

When B Lights of a Light Project enter the Scheme, the following contracting process for EU contribution is followed:

- The Partnership Agreement (PA) is modified by an Addendum to include the Light Partners, the information on the Light Project, the respective activities and outputs.
- The PA Addendum is signed by the LB and the Light Partners of the selected Light Project.
- The PA Addendum, together with the de minimis self-declarations from the Light Partners are sent to the JS (see Chapter 4).
- The responsible programme manager of the JS prepares and sends a note on the compliance of the documentation to the MA and the funding automatically comes into effect.

## 9. Implementation and monitoring

### 9.1. Project duration

**Duration of a single Light Project shall be between 6 and 12 months, the period of implementation of project may not start** before the date of the receipt of the Light Project Proposal by the LB but can start after what should be indicated in the proposal together with the final date of the implementation period of the light project.

### 9.2. Sustainability period

**Sustainability period of a Light Project shall be 2 years after completion of Light Project.** Completion date of a Light Project is the day of approval of the Final Report of the Light Project by the Managing Authority.

Light Partners are obliged to sustain and operate developments of the Light Project until the end of sustainability period. Purchased equipment and outputs of works and infrastructure activities cannot be sold within the Light Project sustainability period.

### 9.3. Advance payment

**Light Partners cannot require advance payment** of grants from the B Light Scheme.

### 9.4. Financial guarantee

Light Partners should not provide financial guarantee for the grants requested when applying their Light Project Proposal as they have fulfilled their obligations relating to the payment of social security contributions and the payment of taxes in accordance with the national legal provisions (see Chapter 3.5.).

If a Light Project will be selected Light Partners will be obliged to submit a **declaration on their bank accounts** and by signing the Partnership Agreement Addendum to give unconditional and irrevocable consent to the Managing Authority (in Hungary) and the National Authority (in Croatia) to issue a **prompt collection order** in case of failure of the Light Project part of the respective Light Partner.

In case of a failure of the Light Project part of the respective Light Partner during the time of project implementation due to e.g. becoming bankrupt or being wound up, having affairs administrated by the court, have been entering into an agreement with creditors, having suspended business activities, becoming the subject of proceedings concerning those matters, or being in any analogous situation arising from a similar procedure provided for in national legislation or regulations, the Light Partner cannot receive funding and will not be supported further. In such a case the remaining Light Project part of the remaining Light Partner(s) should be implemented and all activities should be funded as eligible – or if a partner change is possible, the appropriate modifications should be implemented by approval of the SB.

## 9.5. Reporting procedures

### □ Reporting on level of the Light Partners

As the Light Partners are to be considered as regular project partners having signed the Partnership Agreement, they are also required to report their activities and expenditures to the FLC. As the two-step reporting procedure and slow reimbursement – compared to mainstream funding mechanisms – would represent a considerable financing difficulty to the Light Partner SMEs, reporting shall take place in four-month periods. The EPSF provides the Light Partners technical assistance in the reporting process. Besides document-based checks each Light Partner has to undergo minimum one on-the-spot check before issuing the final DoVE.

Partner level control focuses on activities implemented by the Light Partner in the project period and related expenditures occurred. Detailed guidelines, including the types of documents needed for proving the eligibility of cost items are to be communicated on national level.

### □ Scheme level reporting

Payment of the EU co-financing is linked to submission and approval of regular progress reports. Reporting in case of the Scheme is also in line with the Lead Beneficiary principle. As the partnership is composed of Light Partners as well, reporting procedure should be speeded up in order to make four-month periods applicable and avoid overlapping between the consecutive reporting periods. Submission and approval of the progress and final reports shall take place through the IMIS system.

The project level report is based on the verified costs declared in the DoVEs of the Beneficiaries and the Light Partners and detailed description shall be given on the implemented activities in the given period, including the achievement of relevant indicators. Content of the report has to be justified with the relevant evidences. In case of missing or unclear information the JS issues request for clarification. The JS has the right to ask for exceptional reports in between reporting periods and ask information on progress of the project in general at any time during the implementation.

In spending of the funds available for the Scheme is not carried out in line with the Scheme's payment forecast, the MA may ask interim progress reports. In case of severe deviation from the planned spending forecast, budget of the Scheme may be reduced, including the budget of the problematic Light Projects (decommitment rule – Article 76 of the CPR).

Taking into consideration the length of the two-level control, payment of co-financing may take place in 120-150 days following the end of each reporting period.

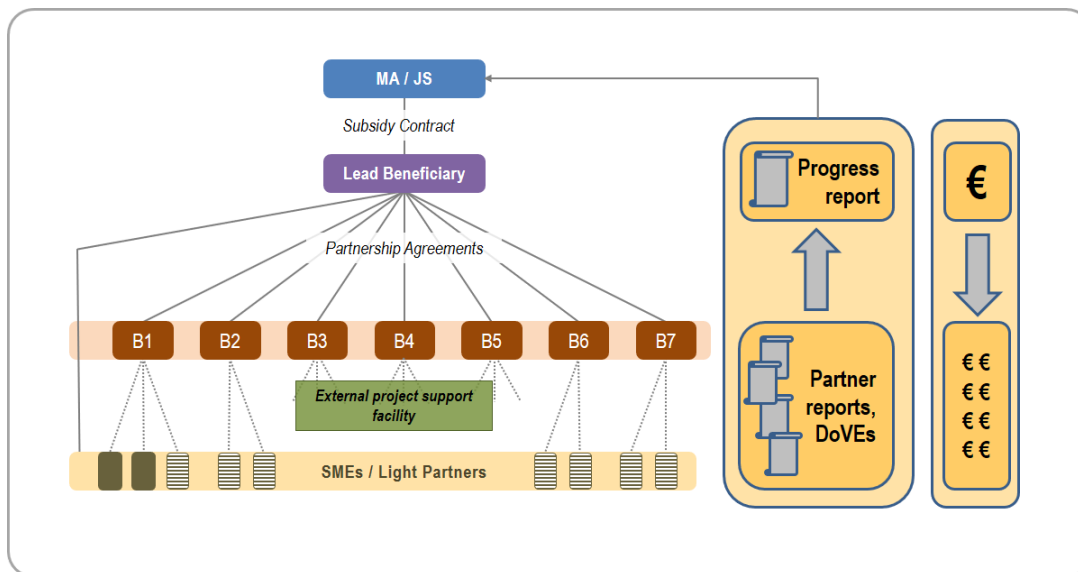

Figure 6: Flow of reporting and payment of co-financing.

## 9.6. Role of the EPSF during management and reporting

Taking into consideration the complex administrative requirements of cross-border project management, free-of-charge technical assistance of External Project Support Facility (EPSF) is provided for Light Partners for coping with these requirements. Lead Beneficiary has the role of appointing External Project Support Facility (EPSF) experts to the Light Partners of granted Light Projects. Acceptance of EPSF technical assistance is a prerequisite of granting the Light Projects.

EPSF experts provide technical assistance to management of Light Project parts of Light Partners in the following fields:

- timing of Light Project activities to be implemented;
- checking of documents of expenditures of Light Partners;
- compilation of partner level progress reports of Light Partners;
- preparation for controlling of First Level Control (including document-based and on-the-spot checks);
- preparation of documentation in case of modification of Light Project.

EPSF does not take over the responsibility of Light Project management from Light Partners but the Lead Beneficiary supervises its activity in light of successfulness of Light Projects' implementation.

## 9.7. Procurement rules

According to Regulation (EU, Euratom) No 966/2012 of the European Parliament and of the Council of 25 October 2012 on the financial rules applicable to the general budget of the Union and repealing Council Regulation (EC, Euratom) No 1605/2002, and based on other regulations relevant to the Cooperation



Programme, each contracted project has to manage procurements of services, supplies / goods / equipment and works in accordance with national procurement rules in force, depending on the seat and operational area of the given organisation (in Hungarian: Közbeszerzési törvény, in Croatian: Zakon o javnoj nabavi).

This means that the public procurement rules have to be applied also in the B Light Scheme, for all project partners, also including Light Partners.

In case of procurements that are not subject to public procurement (e.g. below the financial threshold for public procurement), but the value of the procurement reaches EUR 5,000 (excluding VAT), Light Partners are required to conduct a procurement procedure, and select a contractor among at least three independent proposals.

Under the value of EUR 5,000 (excluding VAT) no procurement procedure is required.

## 9.8. Communication requirements

The communication requirements for the Beneficiaries are contained in the CPR and in Commission Implementing Regulation (EU) No 821/2014.

The Beneficiaries are required to:

- ensure that those taking part in the project have been informed of the funding from the present Programme,
- provide clear notice to the effect that the project being implemented has been selected under the present Programme,
- ensure a statement included in any document, attendance or other certificate about the effect that the Programme was financed by the EU,
- when communicating on all the matters related to the project, the Beneficiaries should use their normal stationery but should always use the logo of the Programme, as well as the Interreg EU logo (see below).

Light Partners are obliged to:

- use both the Programme logo and the Interreg logo with the ERDF reference (as described in the Project Communication Guidelines) and in the respective language (English, Hungarian and/or Croatian) when using any of the communication tools and whenever communication and promoting project results as well as the results of the Programme;
- place at least one poster with information about the project (minimum size A3), including the financial support from the EU, at a location readily visible to the public such as the entrance area of a building.



7. Figure: The combined programme logo to be used on communication tools.

The programme slogan is highly recommended to be used where applicable and in the respective language (English, Hungarian and/or Croatian): “A cross-border region where rivers connect, not divide”.

Among communication tools, **each Light Project has to:**

- have at least one communication event;
- produce trilingual (English, Croatian, Hungarian) promotional material (leaflet, brochure);
- share information on their Light Project on the Light Partners’ websites or social media interfaces;
- have at least one media activity (press release, media broadcast etc.) during the Light Project.

It is strongly recommendable at the beginning of the Light Project to establish a sub-page on the Light Partners’ websites or social media interfaces for continuous information sharing about the cooperation activities.

The Interreg V-A Hungary-Croatia Cross-border Cooperation Programme has got a detailed Project Communication Guidelines that have to be applied during the implementation of the Light Projects as well.

## 10. Administrative requirements for infrastructure and works elements of Light Project

### 10.1. Documents to be attached in case of Light Projects with infrastructure and works elements

Works activities are only eligible if they are directly linked to the cooperation activity carried out by the Light Partners.

In case of Light Projects with works elements, the following documents have to be attached (uploaded together with the Light Project Proposal form, the Certification Statement and the relevant CVs):

Name of document	Description	Language	Original or copy
Land or building registration certificate (tulajdoni lap, ZK uložak)	Land or building registration certificates – certified by the legally authorised representative of the Light Partner implementing the works activity – one document per item (land, building) – must not be older than 30 days at the time of the submission.	In the original language.	Printed and scanned  or  digital file (pdf) directly downloaded from online information system.
Necessary documentation about proof of ownership of land or buildings	See Chapter 10.2.	In the original language.	Printed and scanned.
Documents supporting the financial aspects of construction activities	Detailed cost estimation by type of work, issued by a designer (tervezői költségbecslés / procjena troškova koju izdaje projektant), indicating the main activities and within these the unit prices and the costs of materials and works  or  Detailed price quotations (árajánlat / troškovnik), issued by a contractor, indicating unit prices and the costs of materials and works.	In the original language.	Printed, signed, scanned.

Name of document	Description	Language	Original or copy
Construction plans (engineering plans, descriptions), in line with the relevant legislation in force in Hungary / Croatia	<p>Construction plans (tervdokumentáció / građevinski planovi), submitted for the building permit (építési engedély / građevinska dozvola)</p> <p>or</p> <p>In case the works activity is not subject to permission, the Light Partner should submit the technical description (műszaki leírás / tehnički opis), the diagrammatical plan (vázrajz / dijagramatski prikaz) and the general plan of the building site (átnézeti helyszínrajz / geografska karta (zemljovid) područja gradilišta) with the lot number(s) indicated.</p>	In the original language.	<p>Printed and scanned</p> <p>or</p> <p>drawings in form of digital file (dwg or pdf).</p>
<p>Building permits</p> <p>or</p> <p>Documents certifying the exemption of the construction from building permit<sup>5</sup></p>	<p>Building permits, if already obtained</p> <p>or</p> <p>Notification of the procedure initiated for obtaining the building permit, certified by the respective authority in Hungary / responsible body in Croatia (authority / body responsible for issuing building permits)</p> <p>or</p> <p>Declaration certifying the exemption of the construction from building permit (igazolás, hogy az építkezés nem engedélyköteles / potvrda o izuzeću građevinske aktivnosti od potrebe ishodenja građevinske dozvole): issued by the designer or by the respective authority in Hungary; or issued by the responsible body in Croatia</p>	In the original language.	Printed and scanned.

<sup>5</sup>Please note that the legally binding building permit will be a prerequisite for signing the Partnership Agreement.

Name of document	Description	Language	Original or copy
Photo documentation	The scene of the works activities has to be documented on photos	Not relevant.	Digital files.
Geographical map of the investment site	A geographical map of the construction / reconstruction / building site (HU: átnézeti helyszínrajz) with clear identification of lot number(s) (territories / building sites and/or river sections)	In the original language.	Printed map scanned or digital map.

## 10.2. Ownership issues of land and buildings subject to infrastructure and works components of projects

In case of infrastructure/works development Light Projects, Light Partners must prove the quality of ownership or usage rights of the land and/or building involved in the works component. The ownership has to be proven by a land or building registration certificate from the relevant public registers, according to the national legislation.

Three cases can be distinguished:

1. In case the land or building is owned by the Light Partner implementing the works component, the investment is implemented on own property and only a land or building registration certificate from the relevant public register (HU: tulajdoni lap, HR: ZK uložak) is necessary.
2. Situations can arise where the land or building is not in the exclusive ownership (közös tulajdon / zajedničko vlasništvo) of the Light Partner implementing the works component. In these cases the written consent of the joint proprietors (tulajdonostársak / suvlasništvo) has to be attached to the Light Project Proposal; in the document they must express that they agree with the implementation of the Light Project and with the continuation of operation until 2 years from the end date of the Light Project's implementation period.

If the land or building constitutes a piece of undivided joint property (osztatlan közös tulajdon / nedjeljiv zajednički posjed), the usage agreement (használati szerződés / ugovor o pravu uporabe) between the joint proprietors, stipulated in a notarial document or private law contract of equal probative value (közjegyzői okirat vagy azonos bizonyító erejű magánokirat / javnobilježnički akt ili privatnopravni ugovor jednake dokazne vrijednosti), as well as the drawing about the functional division of the property (vázrajz a vagyontárgy funkcionális megosztásáról / nacrt funkcionalne podjele posjeda) have to be submitted together with the Light Project Proposal.

3. In case the land or building is not owned by the Light Partner implementing the works component, the Light Project could finance developments on a third party's property. In these cases the owner of the land and the Light Partner implementing the works component have to conclude a detailed rent contract (bérleti szerződés / ugovor o najmu) which must be annexed to the Light Project Proposal, together with the declaration of the owner of the property (tulajdonos hozzájáruló nyilatkozata / izjava vlasnika o suglasnosti) that it agrees with the submission of the Light Project Proposal, with the implementation and the subsequent operation for at least 2 years after the end date of the Light Project's implementation period. This rent contract must not contain provision for unilaterally withdrawal by either of the parties. LB should be informed by any substantial modifications of the rent contract.

In all cases the building and/or the land must:

- not be the object of a claim (igénymentes / nije predmet zahtjeva) according to the relevant national legislation,
- not be the object of pending litigation (permentes / nije predmet parnice).

The land or building is not an object of a claim if nobody has a claim, for the present or for the future, listed in the register (nyilvántartásban bejegyzett igény / zabilježba zahtjeva u registru) that could in any way and to any extent hinder the present or future owner of the property in exercising his or her ownership and usage rights. The developed building or infrastructure cannot be sold and must be kept free of all liens and claims for 2 years after the end of the Light Project's period of implementation.

A claim is e.g. if on the extract from the register of the property in question one of the following entries [bejegyzés, széljegyzet / upis, uknjižba (u javni registar)] can be found:

- purchasing right (vételi jog / pravo prvokupa), repurchasing right (visszavásárlási jog / pravo nazadkupa),
- forcible collection right (végrehajtási jog / pravo prisilne naplate),
- existence of a winding-up or liquidation procedure against the owner (felszámolás vagy végelszámolás / stečajni postupak),
- a construction or parcel-establishing prohibition (építési vagy telekalakítási tilalom / zabrana parceliranja ili gradnje) based on a court or administrative decision, other construction restrictions (építési korlátozások / ograničenje gradnje),
- commencement of a parcel-establishing or expropriating procedure (telekalakítási vagy kisajátítási eljárás / postupak parceliranja ili eksproprijacije),
- appointing of an auction procedure (árverés / dražbeni postupak),
- closure (zárlat / obustava poslovanja),
- purchase with the retention of ownership (tulajdonjog fenntartással való adásvétel / prodaja s pridržavanjem prava vlasništva),
- suspension of a register procedure (felfüggesztett telekkönyvi eljárás / suspenzija upisa u zemljišne knjige).

By the end of an investment type Light Project's period of implementation, and for the approval of the Final Project Progress Report, the following documents have to be submitted next to the report:

- record of the technological delivery session (műszaki átadás-átvétel jegyzőkönyve / zapisnik s tehničke primopredaje), together with the statement of the responsible architectural supervisor (felelős műszaki vezető nyilatkozata / izjava nadležnog građevinskog nadzora),
- valid permission of use (hatályos használatbavételi engedély / valjana uporabna dozvola) or a temporary permission of use (ideiglenes használatbavételi engedély / privremena uporabna dozvola) or the

documentation (provided by the relevant authority) proving that the Light Partner has handed in its request for the initialisation of the permission procedure,

- operational water rights licence (vízjogi működési engedély), if relevant.

## Glossary

*Lead Beneficiary (LB):* HAMAG-BICRO, bears responsibility for overall coordination of the implementation of the Scheme, in line with the Subsidy Contract signed with the MA (see Chapter 2.2.).

*Beneficiaries (Bs):* the 7 county level SME development agencies responsible for coordinating the project activities in their respective counties (see Chapter 2.2.).

*Project Partners (PPs):* the LB and the 7 Bs of B Light Scheme project.

*Light Partners (“B Lights”):* SMEs taking part in a Light Project Proposal submitted to the respective Call for Proposals and SMEs as Project Partners (final beneficiaries) of B Light Scheme project. Light Partners can also be referred to as “B Lights”.

*Light Project Proposal:* project proposal submitted by cooperating SMEs for the B Light Scheme Call for Proposal.

*Light Project:* project part of the B Light Scheme project granted through a one-step selection procedure, comprising eligible activities of cooperating Light Partners.

*Subsidy Contract:* Contract signed by the Lead Beneficiary and the Managing Authority for implementation of B Light Scheme project implemented under Priority 1 of Interreg V-A Hungary-Croatia Co-operation Programme 2014-2020.

*Application Pack:* consists of the Guidelines for Light Partner Applicants, the B Light Scheme Call for Proposal (Call for Light Project Proposals, Light Project Proposal Form).

*Implementation Pack:* consists of the Implementation Handbook, the Lead Beneficiary and the Beneficiaries and the Implementation Handbook for the Light Partners and the Communication Plan of the B Light Scheme.



# ANNEX I.

26.10.2012

EN

Official Journal of the European Union

C 326/333

## ANNEX I

### LIST REFERRED TO IN ARTICLE 38 OF THE TREATY ON THE FUNCTIONING OF THE EUROPEAN UNION

(1) No in the Brussels nomenclature	(2) Description of products
Chapter 1	Live animals
Chapter 2	Meat and edible meat offal
Chapter 3	Fish, crustaceans and molluscs
Chapter 4	Dairy produce; birds' eggs; natural honey
Chapter 5	
05.04	Guts, bladders and stomachs of animals (other than fish), whole and pieces thereof
05.15	Animal products not elsewhere specified or included; dead animals of Chapter 1 or Chapter 3, unfit for human consumption
Chapter 6	Live trees and other plants; bulbs, roots and the like; cut flowers and ornamental foliage
Chapter 7	Edible vegetables and certain roots and tubers
Chapter 8	Edible fruit and nuts; peel of melons or citrus fruit
Chapter 9	Coffee, tea and spices, excluding maté (heading No 09.03)
Chapter 10	Cereals
Chapter 11	Products of the milling industry; malt and starches; gluten; inulin
Chapter 12	Oil seeds and oleaginous fruit; miscellaneous grains, seeds and fruit; industrial and medical plants; straw and fodder
Chapter 13	
ex 13.03	Pectin
Chapter 15	
15.01	Lard and other rendered pig fat; rendered poultry fat
15.02	Unrendered fats of bovine cattle, sheep or goats; tallow (including 'premier jus') produced from those fats
15.03	Lard stearin, oleostearin and tallow stearin; lard oil, oleo-oil and tallow oil, not emulsified or mixed or prepared in any way
15.04	Fats and oil, of fish and marine mammals, whether or not refined
15.07	Fixed vegetable oils, fluid or solid, crude, refined or purified
15.12	Animal or vegetable fats and oils, hydrogenated, whether or not refined, but not further prepared

(1) No in the Brussels nomenclature	(2) Description of products
15.13	Margarine, imitation lard and other prepared edible fats
15.17	Residues resulting from the treatment of fatty substances or animal or vegetable waxes
Chapter 16	Preparations of meat, of fish, of crustaceans or molluscs
Chapter 17	
17.01	Beet sugar and cane sugar, solid
17.02	Other sugars; sugar syrups; artificial honey (whether or not mixed with natural honey); caramel
17.03	Molasses, whether or not decolourised
17.05 (*)	Flavoured or coloured sugars, syrups and molasses (including vanilla sugar or vanillin), with the exception of fruit juice containing added sugar in any proportion
Chapter 18	
18.01	Cocoa beans, whole or broken, raw or roasted
18.02	Cocoa shells, husks, skins and waste
Chapter 20	Preparations of vegetables, fruit or other parts of plants
Chapter 22	
22.04	Grape must, in fermentation or with fermentation arrested otherwise than by the addition of alcohol
22.05	Wine of fresh grapes; grape must with fermentation arrested by the addition of alcohol
22.07	Other fermented beverages (for example, cider, perry and mead)
ex 22.08 (*)	Ethyl alcohol or neutral spirits, whether or not denatured, of any strength, obtained from agricultural products listed in Annex I, excluding liqueurs and other spirituous beverages and compound alcoholic preparations (known as 'concentrated extracts') for the manufacture of beverages
ex 22.09 (*)	
22.10 (*)	Vinegar and substitutes for vinegar
Chapter 23	Residues and waste from the food industries; prepared animal fodder
Chapter 24	
24.01	Unmanufactured tobacco, tobacco refuse
Chapter 45	
45.01	Natural cork, unworked, crushed, granulated or ground; waste cork

(1) No in the Brussels nomenclature	(2) Description of products
Chapter 54	
54.01	Flax, raw or processed but not spun; flax tow and waste (including pulled or gametted rags)
Chapter 57	
57.01	True hemp ( <i>Cannabis sativa</i> ), raw or processed but not spun; tow and waste of true hemp (including pulled or gametted rags or ropes)

(\*) Entry added by Article 1 of Regulation No 7a of the Council of the European Economic Community of 18 December 1959 (OJ No 7, 30.1.1961, p. 71/61).

## ANNEX II.

### Light Project Proposal Checklist for administrative criteria

Reference	Name of supporting document	Relevant	Not relevant	Piece(s)	Completion possible
<b>LPP</b>	Light Project Proposal form MS Excel version	Yes			No
<b>LPP 2</b>	Light Project Proposal form Certification sheet signed, scanned	Yes			No
<b>LPP 3</b>	Declarations on de minimis aid of Light Partners	Yes			No
<b>LPP 4</b>	Curriculum Vitae (CV) of the relevant project teammembers				Yes

All cells in the Light Project Proposal form are filled-in Form is completely filled in in English	No
Scanned Certification sheet is signed by the legally authorised representatives Declarations on de minimis aid are completely filled-in and signed	No
Curriculum Vitae are provided in English and in the required form	Yes

<b>LPP</b>	Land or building registration certificates ( <i>tulajdoni lap, ZK uložak</i> ), one per item (land, building)				Yes
<b>LPP</b>	Necessary documentation about proof of ownership of land or buildings (see Chapter 10.2.)				Yes
<b>LPP</b>	Documents supporting the financial aspects of construction activities (detailed cost estimation/ detailed price quotation)				Yes
<b>LPP</b>	Construction plans (engineering plans, descriptions) or (in case the works activity is not subject to permission) technical description, diagrammatical plan and general plan of the building site, with the lot number(s) indicated				Yes

Reference	Name of supporting document	Relevant	Not relevant	Piece(s)	Completion possible
LPP W5	Building permits or notification of the procedure initiated for obtaining the building permit or documents certifying the exemption of the construction from building permit				Yes
LPP W6	Photo documentation, with photographs identifiable through the indication of a lot number and/or street name and house number				Yes
LPP W7	Geographical map of the investment site				Yes

**Light Project Proposal**  
**Checklist for eligibility criteria**

Criteria	Proof	Check	Clarification possible
<ul style="list-style-type: none"> <li>Light Partner or its owner company having more than 50% of ownership rights over the Light Partner or its linked enterprise through a natural person having at least one closed business year</li> </ul>	Public registry		Yes
<ul style="list-style-type: none"> <li>Light Partner or its owner company having more than 50% of ownership rights over the Light Partner or its linked enterprise through a natural person employed at least one employee in its last closed business year</li> </ul>	Public registry		Yes
<ul style="list-style-type: none"> <li>Light Partner's equity is positive for the last closed business year</li> </ul>	Public registry		Yes
<ul style="list-style-type: none"> <li>Light Partners should have their seat or its branch and should operate in the programme area</li> </ul>	Public registry		Yes
<ul style="list-style-type: none"> <li>At least one Light Partner should have its seat or its branch and should operate in the Hungarian programme area</li> </ul>	Public registry		Yes
<ul style="list-style-type: none"> <li>At least one Light Partner should have its seat or its branch and should operate in the Croatian programme area</li> </ul>	Public registry		Yes

<b>Exclusion criteria</b>			
<b>Criteria</b>	<b>Proof</b>	<b>Check</b>	<b>Clarification possible</b>
<ul style="list-style-type: none"> <li>Enterprises active in the following sectors (gaining more than 50% of their annual turnover from these sectors in their past closed business year) are excluded:               <ul style="list-style-type: none"> <li>NACE code A – Agriculture, forestry and fishing (01 – 03).</li> </ul> </li> </ul>	Public registry		Yes
<ul style="list-style-type: none"> <li>Light Projects containing development of the following activities:               <ul style="list-style-type: none"> <li>fishery and aquaculture,</li> <li>primary production, processing and marketing of agricultural products listed in Annex I to the Treaty (see Annex I of Guidelines for Light Partner Applicants),</li> <li>the establishment and operation of a distribution network towards third countries or Member States;</li> </ul> </li> </ul>	, Light Project Proposal form		Yes
<ul style="list-style-type: none"> <li>Eligible activities of Light Project business cooperation do not belong to the NACE codes representing the target economic sectors of B Light Scheme (see Chapter 5.1.);</li> </ul>	Light Project Proposal form		Yes
<ul style="list-style-type: none"> <li>Their business is in difficult situation (according to Regulation 800/2008/EK);</li> </ul>	Declaration		Yes
<ul style="list-style-type: none"> <li>They are bankrupt, being wound up, liquidated or having their affairs administered by the courts</li> </ul>	Declaration		Yes
<ul style="list-style-type: none"> <li>They have entered into an agreement with creditors</li> </ul>	Declaration		Yes
<ul style="list-style-type: none"> <li>They have suspended business activities</li> </ul>	Declaration		Yes
<ul style="list-style-type: none"> <li>They are subject of proceedings concerning those matters, or are in any analogous situation arising from a similar procedure provided for in national legislation or regulations</li> </ul>	Declaration		Yes

Criteria	Proof	Check	Clarification possible
<ul style="list-style-type: none"> <li>• They do not have valid registration to pursue their activities or they have been convicted of an offence concerning their professional conduct by a judgement which has the force of 'res iudicata', further they have been guilty of grave professional misconduct proven by any means which the MA/NA can justify</li> </ul>	Declaration		Yes
<ul style="list-style-type: none"> <li>• They have not fulfilled their obligations relating to the payment of social security contributions or the payment of taxes in accordance with the national legal provisions</li> </ul>	Public registry		Yes
<ul style="list-style-type: none"> <li>• They have been the subject of a judgement which has the force of 'res iudicata' for fraud, for corruption, for severe breach of contract in connection to obligations stemming from public procurement rules or from rules governing the use of Community funding or national subsidies, for involvement in a criminal organisation or for any other illegal activity detrimental to the Community's financial interests</li> </ul>	Declaration		Yes
<ul style="list-style-type: none"> <li>• They are subject to a conflict of interests connected to their participation in the present B Light Scheme</li> </ul>	Declaration		Yes
<ul style="list-style-type: none"> <li>• They are guilty of misrepresentation in supplying the information required by the LB/MA/NA as a condition of participation in the Scheme or in failing to supply information</li> </ul>	Declaration		Yes
<ul style="list-style-type: none"> <li>• They have attempted to obtain confidential information or to influence the Selection Board during the evaluation process of their Light Project Proposal</li> </ul>	Declaration		Yes